

Class IX Chapter 1 – Number Systems Maths

Exercise 1.1 Question

Is zero a rational number? Can you write it in the form $\frac{p}{q}$, where p and q are integers $\neq 0$ and q

Answer:

Yes. Zero is a rational number as it can be represented as $\frac{0}{1}$ or $\frac{0}{2}$ or $\frac{0}{3}$ etc.

Question 2:

Find six rational numbers between 3 and 4.

Answer:

There are infinite rational numbers in between 3 and 4.

3 and 4 can be represented as $\frac{24}{8}$ and $\frac{32}{8}$ respectively.

Therefore, rational numbers between 3 and 4 are

$\frac{25}{8}, \frac{26}{8}, \frac{27}{8}, \frac{28}{8}, \frac{29}{8}, \frac{30}{8}$

Question 3:

Find five rational numbers between $\frac{3}{5}$ and $\frac{4}{5}$.

There are infinite rational numbers between $\frac{3}{5}$ and $\frac{4}{5}$.

$$\frac{3}{5} = \frac{3 \times 6}{5 \times 6} = \frac{18}{30}$$

$$\frac{4}{5} = \frac{4 \times 6}{5 \times 6} = \frac{24}{30}$$

numbers between $\frac{3}{5}$ and $\frac{4}{5}$

Therefore, rational numbers are

$$\frac{19}{30}, \frac{20}{30}, \frac{21}{30}, \frac{22}{30}, \frac{23}{30}$$

Question 4:

State whether the following statements are true or false. Give reasons for your answers.

- (i) Every natural number is a whole number.
- (ii) Every integer is a whole number.
- (iii) Every rational number is a whole number.

Answer:

- (i) True; since the collection of whole numbers contains all natural numbers.
- (ii) False; as integers may be negative but whole numbers are positive. For example: -3 is an integer but not a whole number.

- (iii) False; as rational numbers may be fractional but whole numbers may not be. For

example: $\frac{1}{5}$ is a rational number but not a whole number.

Exercise 1.2 Question 1:

State whether the following statements are true or false. Justify your answers.

- (i) Every irrational number is a real number.
- (ii) Every point on the number line is of the form \sqrt{m} , where m is a natural number.
- (iii) Every real number is an irrational number.

Answer:

- (i) True; since the collection of real numbers is made up of rational and irrational numbers.
- (ii) False; as negative numbers cannot be expressed as the square root of any other number.
- (iii) False; as real numbers include both rational and irrational numbers. Therefore, every real number cannot be an irrational number.

Question 2:

Are the square roots of all positive integers irrational? If not, give an example of the square root of a number that is a rational number.

Answer:

If numbers such as $\sqrt{4} = 2$, $\sqrt{9} = 3$ are considered,

Then here, 2 and 3 are rational numbers. Thus, the square roots of all positive integers are not irrational.

Question 3:

$$\sqrt{5}$$

Answer:

$$\sqrt{4} = 2$$

We know that,

$$\sqrt{5} = \sqrt{(2)^2 + (1)^2}$$

Show how And, $\sqrt{5}$ can be represented on the number line.

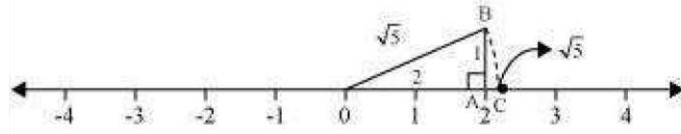

Mark a point 'A' representing 2 on number line. Now, construct AB of unit length perpendicular to OA. Then, taking O as centre and OB as radius, draw an arc intersecting number line at C.

C is representing $\sqrt{5}$.

has:

(i) $\frac{36}{100}$ (ii) $\frac{1}{11}$ (iii) $4\frac{1}{8}$

(iv) $\frac{3}{13}$ (v) $\frac{2}{11}$ (vi) $\frac{329}{400}$

Answer:

(i) $\frac{36}{100} = 0.36$

Terminating

(ii) $\frac{1}{11} = 0.090909\dots = 0.\overline{09}$

Non-terminating repeating

(iii) $4\frac{1}{8} = \frac{33}{8} = 4.125$

Terminating

(iv) $\frac{3}{13} = 0.230769230769\dots = 0.\overline{230769}$

Non-terminating repeating

(v) $\frac{2}{11} = 0.18181818\dots = 0.\overline{18}$

Non-terminating repeating

(vi) $\frac{329}{400} = 0.8225$

Terminating

$\frac{1}{7} = 0.\overline{142857}$ Question 2:

You know that

$\frac{2}{7}, \frac{3}{7}, \frac{4}{7}, \frac{5}{7}, \frac{6}{7}$

Exercise 1.3 Question 1:

Write the following in decimal form and say what kind of decimal expansion each . Can you predict what the decimal expansion of are, without actually doing the long division? If so, how?

[Hint: Study the remainders while finding the value of $\frac{1}{7}$ carefully.] Answer:

Yes. It can be done as follows.

$$\frac{2}{7} = 2 \times \frac{1}{7} = 2 \times 0.\overline{142857} = \overline{0.285714}$$

, where p and q are integers and q \neq 0.

$$\frac{3}{7} = 3 \times \frac{1}{7} = 3 \times 0.\overline{142857} = \overline{0.428571}$$

$$10x = 6 + x$$

$$\frac{4}{7} = 4 \times \frac{1}{7} = 4 \times 0.\overline{142857} = \overline{0.571428}$$

$$9x = 6$$

$$x = \frac{2}{3}$$

$$\frac{5}{7} = 5 \times \frac{1}{7} = 5 \times 0.\overline{142857} = \overline{0.714285}$$

$$(ii) \quad \overline{0.47} = 0.4777\dots$$

$$\frac{6}{7} = 6 \times \frac{1}{7} = 6 \times 0.\overline{142857} = \overline{0.857142}$$

$$= \frac{4}{10} + \frac{0.777}{10}$$

Question 3:

$$\frac{p}{q} \quad \text{Let } x = 0.777\dots$$

$$10x = 7.777\dots$$

Express the following in the form $\frac{p}{q}$

$$10x = 7 + x$$

- (i) $0.\overline{6}$ (ii) $0.4\overline{7}$ (iii) $0.00\overline{1}$

$$x = \frac{7}{9}$$

Answer:

$$\begin{aligned} \frac{4}{10} + \frac{0.777\dots}{10} &= \frac{4}{10} + \frac{7}{90} \\ &= \frac{36+7}{90} = \frac{43}{90} \end{aligned}$$

(i) $0.\overline{6} = 0.666\dots$

Let $x = 0.666\dots$

$10x = 6.666\dots$

(iii) $0.00\overline{1} = 0.001001\dots$

Let $x = 0.001001\dots$

$1000x = 1.001001\dots$

$1000x = 1 + x$

$999x = 1$

$x = \frac{1}{999}$

Question 4:

$\frac{p}{q}$

Express $0.99999\dots$ in the form $\frac{p}{q}$. Are you surprised by your answer? With your teacher and classmates discuss why the answer makes sense.

Answer:

Let $x = 0.9999\dots$

$$10x = 9.9999\dots$$

$$10x = 9 + x$$

$$9x = 9 \times =$$

$$1$$

Question 5:

What can the maximum number of digits be in the repeating block of digits in the decimal expansion of $\frac{1}{17}$? Perform the division to check your answer.

Answer:

It can be observed that,

$$\frac{1}{17} = 0.0588235294117647$$

There are 16 digits in the repeating block of the decimal expansion of $\frac{1}{17}$.

Question 6:

Look at several examples of rational numbers in the form $\frac{p}{q}$ ($q \neq 0$), where p and q are integers with no common factors other than 1 and having terminating decimal representations (expansions). Can you guess what property q must satisfy?

Answer:

Terminating decimal expansion will occur when denominator q of rational number $\frac{p}{q}$ is either of 2, 4, 5, 8, 10, and so on...

$$\frac{9}{4} = 2.25$$

$$\frac{11}{8} = 1.375$$

$$\frac{27}{5} = 5.4$$

It can be observed that terminating decimal may be obtained in the situation where prime factorisation of the denominator of the given fractions has the power of 2 only or 5 only or both.

Question 7:

Write three numbers whose decimal expansions are non-terminating non-recurring.
Answer:

3 numbers whose decimal expansions are non-terminating non-recurring are as follows.

0.505005000500005000005...

0.7207200720007200007200000... 0.080080008000080000080000008...

Question

8:

$$\frac{5}{7} \quad \frac{9}{11}$$

Find three different irrational numbers between the rational numbers $\frac{5}{7}$ and $\frac{9}{11}$. Answer:

$$\frac{5}{7} = 0.\overline{714285}$$

$$\frac{9}{11} = 0.\overline{81}$$

3 irrational numbers are as follows.

0.73073007300073000073...

0.75075007500075000075... 0.79079007900079000079...

Question

9:

Classify the following numbers as rational or irrational:

(i) $\sqrt{23}$ (ii) $\sqrt{225}$ (iii) 0.3796

(iv) 7.478478 (v) 1.101001000100001...

(i) $\sqrt{23} = 4.79583152331 \dots$

As the decimal expansion of this number is non-terminating non-recurring, therefore, it

is an irrational number.

(ii) $\sqrt{225} = 15 = \frac{15}{1}$

It is a rational number as it can be represented in $\frac{p}{q}$ form.

(iii) 0.3796

As the decimal expansion of this number is terminating, therefore, it is a rational number.

(iv) $7.478478 \dots = \overline{7.478}$

As the decimal expansion of this number is non-terminating recurring, therefore, it is a rational number.

(v) 1.10100100010000 ...

As the decimal expansion of this number is non-terminating non-repeating, therefore, it is an irrational number.

Exercise 1.4 Question

1:

Visualise 3.765 on the number line using successive magnification.

Answer:

3.765 can be visualised as in the following steps.

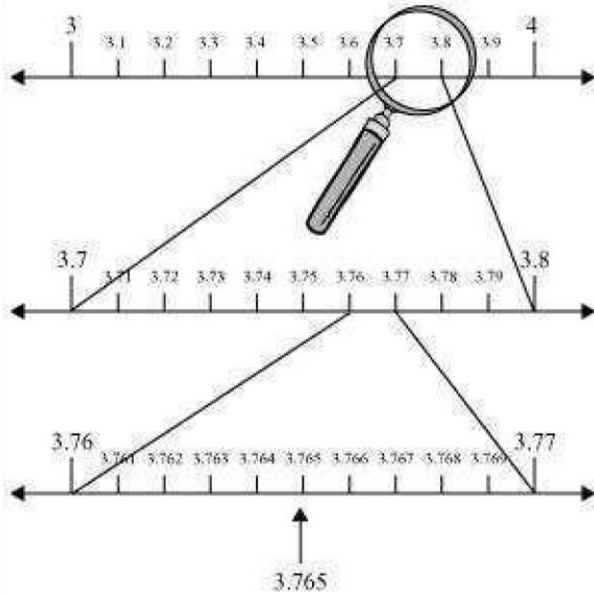

Question 2:

Visualise $4.\overline{26}$ on the number line, up to 4 decimal places.

Answer:

$$4.\overline{26} = 4.2626\dots$$

4.2626 can be visualised as in the following steps.

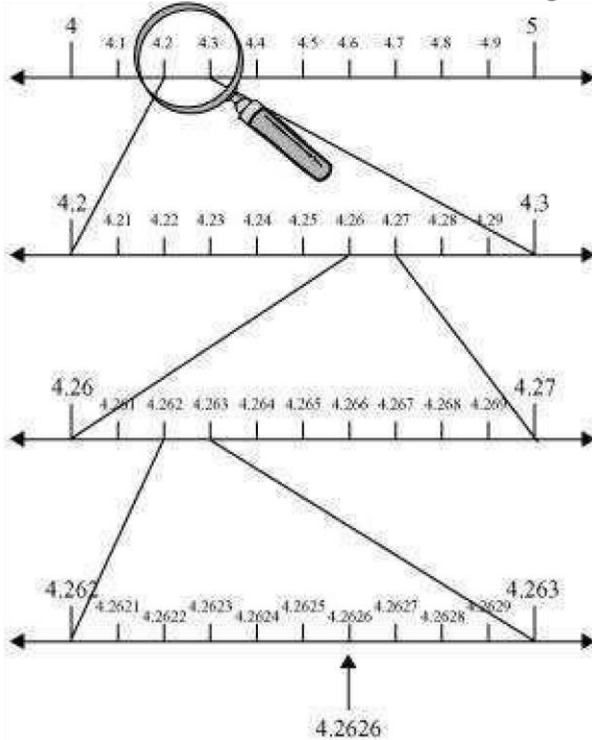

Exercise 1.5 Question 1:

1 Classify the following numbers as rational or irrational:

(i) $2 - \sqrt{5}$ (ii) $(3 + \sqrt{23}) - \sqrt{23}$ (iii) $\frac{2\sqrt{7}}{7\sqrt{7}}$

(iv) $\frac{1}{\sqrt{2}}$ (v) 2π

Answer:

(i) $2 - \sqrt{5} = 2 - 2.2360679...$
 $= -0.2360679...$

As the decimal expansion of this expression is non-terminating non-recurring, therefore, it is an irrational number.

form, therefore, it is a rational

$$(ii) \quad (3 + \sqrt{23}) - \sqrt{23} = 3 = \frac{3}{1}$$

$$\frac{p}{q}$$

As it can be represented in

$$\frac{2\sqrt{7}}{7\sqrt{7}} = \frac{2}{7}$$

(iii)

$$\frac{p}{q}$$

As it can be represented in

$$(iv) \quad \frac{1}{\sqrt{2}} = \frac{\sqrt{2}}{2} = 0.7071067811...$$

number. form, therefore, it is a

rational number.

As the decimal expansion of this expression is non-terminating non-recurring,

therefore, it is an irrational number. (v)

$$2\pi = 2(3.1415 \dots)$$

$$= 6.2830 \dots$$

As the decimal expansion of this expression is non-terminating non-recurring, therefore,

it is an irrational number.

Question 2:

Simplify each of the following expressions:

$$(i) \quad (3 + \sqrt{3})(2 + \sqrt{2}) \quad (ii) \quad (3 + \sqrt{3})(3 - \sqrt{3})$$

$$(iii) \quad (\sqrt{5} + \sqrt{2})^2 \quad (iv) \quad (\sqrt{5} - \sqrt{2})(\sqrt{5} + \sqrt{2})$$

Answer:

$$(i) \quad (3 + \sqrt{3})(2 + \sqrt{2}) = 3(2 + \sqrt{2}) + \sqrt{3}(2 + \sqrt{2}) \\ = 6 + 3\sqrt{2} + 2\sqrt{3} + \sqrt{6}$$

$$(ii) \quad (3 + \sqrt{3})(3 - \sqrt{3}) = (3)^2 - (\sqrt{3})^2 \\ = 9 - 3 = 6$$

$$(iii) \quad (\sqrt{5} + \sqrt{2})^2 = (\sqrt{5})^2 + (\sqrt{2})^2 + 2(\sqrt{5})(\sqrt{2}) \\ = 5 + 2 + 2\sqrt{10} = 7 + 2\sqrt{10}$$

$$(iv) \quad (\sqrt{5} - \sqrt{2})(\sqrt{5} + \sqrt{2}) = (\sqrt{5})^2 - (\sqrt{2})^2 \\ = 5 - 2 = 3$$

Question 3:

Recall, π is defined as the ratio of the circumference (say c) of a circle to its diameter

(say d). That is, $\pi = \frac{c}{d}$. This seems to contradict the fact that π is irrational. How will you resolve this contradiction?

Answer:

There is no contradiction. When we measure a length with scale or any other instrument, we only obtain an approximate rational value. We never obtain an exact value. For this reason, we may not realise that either c or d is irrational. Therefore,

the $\frac{c}{d}$ fraction is irrational. Hence, π is irrational.

Question 4:

$$\sqrt{9.3}$$

Represent on the number line.

Answer:

Mark a line segment $OB = 9.3$ on number line. Further, take BC of 1 unit. Find the midpoint

D of OC and draw a semi-circle on OC while taking D as its centre. Draw a

- (i) $\frac{1}{\sqrt{7}}$ (ii) $\frac{1}{\sqrt{7}-\sqrt{6}}$
 (iii) $\frac{1}{\sqrt{5}+\sqrt{2}}$ (iv) $\frac{1}{\sqrt{7}-2}$

Answer:

(i) $\frac{1}{\sqrt{7}} = \frac{1 \times \sqrt{7}}{1 \times \sqrt{7}} = \frac{\sqrt{7}}{7}$

perpendicular to line OC passing through point B . Let it intersect the semi-circle at E .

Taking B as centre and BE as radius, draw an arc intersecting number line at F . BF is $\sqrt{9.3}$.

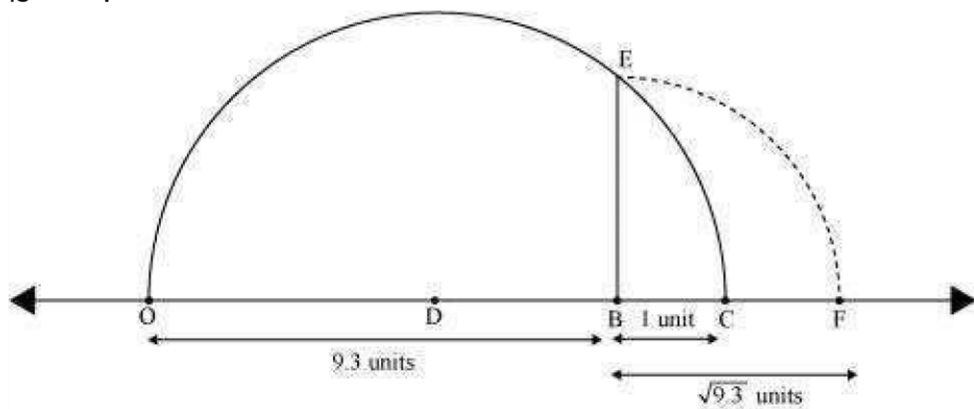

Question 5:

Rationalise the denominators of the following:

$$\frac{1}{\sqrt{7}-\sqrt{6}} = \frac{1}{(\sqrt{7}-\sqrt{6})(\sqrt{7}+\sqrt{6})}$$

(ii)

$$= \frac{\sqrt{7}+\sqrt{6}}{(\sqrt{7})^2 - (\sqrt{6})^2}$$

$$= \frac{\sqrt{7}+\sqrt{6}}{7-6} = \frac{\sqrt{7}+\sqrt{6}}{1} = \sqrt{7}+\sqrt{6}$$

$$\frac{1}{\sqrt{5}+\sqrt{2}} = \frac{1}{(\sqrt{5}+\sqrt{2})(\sqrt{5}-\sqrt{2})}$$

(iii)

$$= \frac{\sqrt{5}-\sqrt{2}}{(\sqrt{5})^2 - (\sqrt{2})^2} = \frac{\sqrt{5}-\sqrt{2}}{5-2}$$

$$= \frac{\sqrt{5}-\sqrt{2}}{3}$$

$$\frac{1}{\sqrt{7}-2} = \frac{1}{(\sqrt{7}-2)(\sqrt{7}+2)}$$

(iv)

$$= \frac{\sqrt{7}+2}{(\sqrt{7})^2 - (2)^2}$$

$$= \frac{\sqrt{7}+2}{7-4} = \frac{\sqrt{7}+2}{3}$$

Exercise 1.6 Question 1:

Find:

(i) $64^{\frac{1}{2}}$ (ii) $32^{\frac{1}{5}}$ (iii) $125^{\frac{1}{3}}$

Find:

(i) $9^{\frac{3}{2}}$ (ii) $32^{\frac{2}{5}}$ (iii) $16^{\frac{3}{4}}$

(iv) $125^{\frac{-1}{3}}$

Answer:

Answer:

(i) $64^{\frac{1}{2}} = (2^6)^{\frac{1}{2}}$
 $= 2^{6 \times \frac{1}{2}}$
 $= 2^3 = 8$

(ii) $32^{\frac{1}{5}} = (2^5)^{\frac{1}{5}}$
 $= (2)^{5 \times \frac{1}{5}}$
 $= 2^1 = 2$

(iii) $(125)^{\frac{1}{3}} = (5^3)^{\frac{1}{3}}$
 $= 5^{3 \times \frac{1}{3}}$
 $= 5^1 = 5$

Question 2:

(i) $9^{\frac{3}{2}} = (3^2)^{\frac{3}{2}}$
 $= 3^{2 \times \frac{3}{2}}$ $[(a^m)^n = a^{mn}]$
 $= 3^3 = 27$

(ii) $(32)^{\frac{2}{5}} = (2^5)^{\frac{2}{5}}$
 $= 2^{5 \times \frac{2}{5}}$ $[(a^m)^n = a^{mn}]$
 $= 2^2 = 4$

(iii) $[(a^m)^n = a^{mn}]$ $(16)^{\frac{3}{4}} = (2^4)^{\frac{3}{4}}$
 $= 2^{4 \times \frac{3}{4}}$ $[(a^m)^n = a^{mn}]$
 $= 2^3 = 8$

(iv) $[(a^m)^n = a^{mn}]$ $(125)^{\frac{-1}{3}} = \frac{1}{(125)^{\frac{1}{3}}}$ $[a^{-m} = \frac{1}{a^m}]$
 $= \frac{1}{(5^3)^{\frac{1}{3}}}$
 $[(a^m)^n = a^{mn}]$ $= \frac{1}{5^{3 \times \frac{1}{3}}}$ $[(a^m)^n = a^{mn}]$
 $= \frac{1}{5}$

Question 3:

Simplify:

$$(i) 2^{\frac{2}{3}} \cdot 2^{\frac{1}{5}} \quad (ii) \left(\frac{1}{3^3}\right)^7 \quad (iii) \frac{11^{\frac{1}{2}}}{11^{\frac{1}{4}}}$$

$$(iv) 7^{\frac{1}{2}} \cdot 8^{\frac{1}{2}}$$

Answer:

(i)

$$\begin{aligned} 2^{\frac{2}{3}} \cdot 2^{\frac{1}{5}} &= 2^{\frac{2}{3} + \frac{1}{5}} && [a^m \cdot a^n = a^{m+n}] \\ &= 2^{\frac{10+3}{15}} = 2^{\frac{13}{15}} \end{aligned}$$

(ii)

$$\begin{aligned} \left(\frac{1}{3^3}\right)^7 &= \frac{1}{3^{3 \times 7}} && [(a^m)^n = a^{mn}] \\ &= \frac{1}{3^{21}} \\ &= 3^{-21} && \left[\frac{1}{a^m} = a^{-m}\right] \end{aligned}$$

(iii)

$$\begin{aligned} \frac{11^{\frac{1}{2}}}{11^{\frac{1}{4}}} &= 11^{\frac{1}{2} - \frac{1}{4}} && \left[\frac{a^m}{a^n} = a^{m-n}\right] \\ &= 11^{\frac{2-1}{4}} = 11^{\frac{1}{4}} \end{aligned}$$

(iv)

$$\begin{aligned} 7^{\frac{1}{2}} \cdot 8^{\frac{1}{2}} &= (7 \times 8)^{\frac{1}{2}} && [a^m \cdot b^m = (ab)^m] \\ &= (56)^{\frac{1}{2}} \end{aligned}$$